



POWER DRIVE 250G INSTRUCTIONS

REIMANN & GEORGER CORPORATION
HOISTING PRODUCTS
P/N 6102074

BUFFALO, NY
06/26/13

PRE-HOISTING CHECKLIST

This checklist must be checked prior to each use of the power drive. This checklist is to be used as a guideline in conjunction with the maintenance and inspection procedures outlined in this manual. The power drive and related equipment must be thoroughly inspected prior to each use by a trained person. A trained person is one who has read and thoroughly understands this instruction manual and related equipment manuals and, through training and experience, has shown knowledge regarding the safe operational procedures. If you do not have such a person in your organization, please contact Reimann & Georger Corporation or its distributors and they will assist you in providing such a “trained person.” Do not permit any person who is not fully trained to operate this power drive. It is recommended that this checklist be maintained as a permanent record.

- Discuss work plan, personal protective equipment, and each crew member’s responsibility before starting to set-up.
- Ensure OSHA compliant fall protection is in place.
- Ensure hoisting operation will clear all power lines and obstructions.
- Ensure hoisting area is secured from all unauthorized personnel.
- Ensure the track is securely tied to the roof to prevent track from slipping.
- Ensure that both track shoes are resting on a firm level surface to prevent track slippage or uneven loading.
- Ensure the load does not exceed the rated load capacity of the hoist model being used.
- Ensure all structural members of the power drive are free of defects and damage that may affect the integrity of the power drive.
- Ensure brake rope is not wet.
- Inspect wire rope for signs of wear and damage. Replace defective wire rope immediately.
- Ensure that at least three wraps of wire rope are on the power drive winch drum at maximum travel.
- Ensure that the screw securing wire rope end loop to the power drive brake sheave is tight and in good condition.
- Ensure wire rope is reeved properly for either one (1) part of line for the 200lb capacity hoist or two (2) parts of line for the 400lb capacity hoist.
- Ensure that track support has been properly installed for track lengths over 28 feet.
- Ensure that the bottom of the track is away from the building $\frac{1}{4}$ of the supported height plus the building overhang.
- Ensure that all bolts and nuts are tightened securely.
- Ensure all sheaves can rotate freely.
- Ensure safety latch on the hook does not support any load.
- Ensure power drive has been properly maintained.
- Operate hoist with no load to test hoisting operation, controls, and power drive.
- Check oil level in both the crankcase and reducer of all gas engine powered units. See chapter 4.2.1 & chapter 6.

INSPECTOR: _____ **DATE:** _____

TABLE OF CONTENTS

CHAPTER	TITLE	PAGE
1	SAFETY	1
1.1	Introduction	1
1.2	Safety Definitions	1
1.3	Power Drive Safety Labels	1
1.4	Power Drive Safety Rules	1
2	SPECIFICATIONS	3
2.1	Power Drive Specifications	3
2.2	Nameplate and Serial Number Tag.....	3
3	INSTALLATION AND SETUP	4
3.1	Prior to Setup.....	4
3.2	Mounting the Power Drive	4
4	OPERATION.....	6
4.1	Before Operating the Power Drive	6
4.2	Power Drive Startup	6
4.2.1	Gas Engine Startup	6
4.2.2	Raising and Lowering the Load	7
4.3	Preparing Power Drive for Shutdown	8
5	DISASSEMBLY	9
5.1	Prior to Disassembly.....	9
6	INSPECTION AND MAINTENANCE.....	10
6.1	General Maintenance Rules.....	10
6.2	Initial Inspection.....	10
6.3	Daily Inspection.....	10
6.4	Clutch-Brake Adjustment.....	11
6.5	Safety Hooks	12
6.6	Oiling Mechanical Parts	12
6.7	Engine Oil Requirements.....	12
6.7.1	Briggs & Stratton Engines.....	12
6.8	Engine Maintenance	13
6.9	Wire Rope Inspection Procedure.....	14
6.10	Replacing Power Drive Wire Rope	15
7	TROUBLESHOOTING.....	16
8	PARTS LISTS.....	17
8.1	Classic 250G Power Drive	17

LIST OF FIGURES

FIGURE	DESCRIPTION	PAGE
2-1	Typical Hoist Product Nameplate.....	3
3-1	Power Drive Installation on Pro Track	5
6-1	Clutch-Brake Adjustment Detail	11
6-2	Wire Rope Components	14
6-3	Power Drive Wire Rope Installation on Brake Sheave	15
8-1	Classic 250G Power Drive Assembly Drawing.....	18

1 SAFETY

1.1 INTRODUCTION

Your Reimann & Georger Corporation Classic 250G Power Drive is engineered to provide lifting performance, long term economics and safety advantages that no other type can match. However, even well designed and well built equipment can malfunction or become hazardous in the hands of an inexperienced and/or untrained user. Therefore, read this manual and related equipment manuals thoroughly before operating your power drive to provide maximum safety for all operating personnel, and to get the maximum benefit from your equipment.

1.2 SAFETY DEFINITIONS

A safety message alerts you to potential hazards that could injure you or others or cause property damage. The safety messages or signal words for product safety signs are **DANGER**, **WARNING**, and **CAUTION**. Each safety message is preceded by a safety alert symbol and is defined as follows:

DANGER: Indicates an imminently hazardous situation which, if not avoided, **will** cause death or serious injury. This safety message is limited to the most extreme situations.

WARNING: Indicates a potentially hazardous situation which, if not avoided, **could** result in death or serious injury.

CAUTION: Indicates a potentially hazardous situation which, if not avoided, **may** result in minor or moderate injury. It may also be used to alert against unsafe practices and property-damage-only accidents.

1.3 POWER DRIVE SAFETY LABELS

These labels warn you of potential hazards that could cause injury. Read them carefully. If a label comes off or becomes illegible, contact Reimann & Georger Corporation for a free replacement.

1.4 POWER DRIVE SAFETY RULES

1. Operators must be trained before operating this power drive. A trained person is one who has read and thoroughly understands this instruction manual and related equipment manuals and, through training and experience, has shown knowledge regarding the safe operational procedures.
2. Prior to setting up the power drive there must be a plan of action outlining the work to be accomplished, individual responsibilities, personal protective equipment, and method of communication.
3. All personnel shall be protected by OSHA compliant fall protection where applicable.
4. Never use the power drive or hoist structure to anchor life lines, worker's harnesses or other attachments.
5. **Always** use safety footwear, safety glasses, and head protection devices.
6. A good line of communication must be maintained between the power drive operator and the roof crew.
7. Hoisting area is to be kept clear of unauthorized personnel at all times. Place barricades or secure the area in such a manner that if there were an equipment failure, no personnel would be injured.
8. Hoisting area is to be clear of power lines. Consult power company before you work near power lines.
9. Follow the Pre-Hoisting Checklist before operating.
10. Wear heavy leather gloves when handling wire rope.
11. Secure load before lifting.

12. Do not remove material from the platform until it has stopped completely.
13. Keep out from under a raised load.
14. Never stand in-line with the raising or lowering of the platform at either the top or bottom of the hoist track.
15. Never hoist over an open doorway.
16. Never exceed the Rated Load Capacity of 200 pounds for the PL250 hoist, or PRO200 hoist, or 400 pounds for the PL400 hoist, or PRO400 hoist. The Rated Load Capacity is the maximum load that should ever be applied to the hoist.
17. Avoid sudden stops and shock loads.
18. No person shall be allowed to ride on the hoist.
19. **NEVER** climb the track; use a ladder.
20. Check the hoist periodically during operation. Know how to stop the power drive quickly in case of emergency.
21. Do not attempt to make adjustments while the hoist is being operated.
22. If the engine fails during operation, release control levers to prevent load from falling.
23. Keep all body parts clear of moving parts.
24. Do not operate power drive when brake rope is wet.
25. Do not operate power drive when under the influence of drugs, alcohol, or medication.
26. At end of operation, the power drive and hoist should be secured to prevent unauthorized use. Never assume you will find the hoist in the same condition in which you left it.
27. Do not weld or otherwise modify the power drive. Such alterations may weaken the structural integrity of the power drive and invalidate your warranty.
28. Only trained personnel are authorized to do repairs.

2 SPECIFICATIONS

2.1 POWER DRIVE SPECIFICATIONS

250G (Gas engine): 4 cycle, 4HP Briggs & Stratton
Wire rope 5/32-in. diameter, 7 x 19 galvanized aircraft wire rope

Note that platform speed and capacity is based on 5/32 inch wire rope diameter. As wire rope builds up on drum, lifting speed increases and lifting capacity decreases in direct proportion to drum diameter.

2.2 NAMEPLATE AND SERIAL NUMBER TAG

It is important to identify your power drive completely and accurately whenever ordering spare parts or requesting assistance in service. The power drive has a product nameplate located on the power drive frame. The label shows the model number, serial number and the capacity rating. The power drive label should appear as the sample nameplate shown in Figure 2-1. Record the model and serial numbers, and capacity rating for future reference.

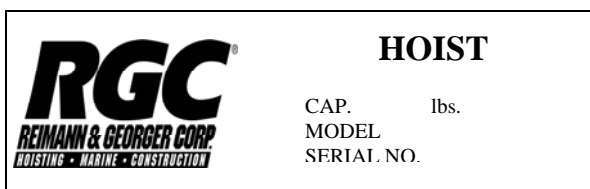

Figure 2-1.
Typical Hoist Product Nameplate

MODEL _____

SERIAL NUMBER _____

CAPACITY RATING _____

3 INSTALLATION AND SETUP

3.1 PRIOR TO SETUP

1. Ensure all structural members of the power drive are free of defects and damage that may affect the integrity of the unit.
2. Ensure the hoisting area is secured from all unauthorized personnel.
3. Referring to Figure 3-1, and the instructions included with the additional cross tie stiffener install a cross tie stiffener in the 5th cross tie from the swivel shoe end of the base track section.



WARNING:

ENSURE THAT OSHA COMPLIANT FALL PROTECTION IS IN PLACE.



WARNING:

PRIOR TO SETTING UP THE HOIST THERE MUST BE A PLAN OF ACTION OUTLINING THE WORK TO BE ACCOMPLISHED, INDIVIDUAL RESPONSIBILITIES, PERSONAL PROTECTIVE EQUIPMENT, AND THE METHOD OF COMMUNICATION. FAILURE TO DO THIS CAN RESULT IN DEATH, SERIOUS PERSONAL INJURY OR EQUIPMENT FAILURE.



WARNING:

ENSURE THAT ALL BOLTS AND NUTS ARE TIGHTENED SECURELY TO PREVENT EQUIPMENT DAMAGE AND/OR SERIOUS INJURY.

3.2 MOUNTING THE POWER DRIVE



WARNING:

THE HOISTING OPERATION MUST BE CLEAR OF ALL ELECTRICAL LINES AND OBSTRUCTIONS TO PREVENT EQUIPMENT DAMAGE AND/OR SERIOUS PERSONAL INJURY. CONSULT POWER COMPANY BEFORE WORKING NEAR POWER LINES.



WARNING:

NEVER CLIMB ON THE TRACK. THIS CAN CAUSE SERIOUS PERSONAL INJURY OR DEATH. USE A LADDER.

4. Mount the power drive in an essentially vertical position. **If the power drive is not vertical, the brake and clutch levers will not work and the engine may not operate.** Referring to Figure 3-1, position the power drive on the 3rd and 5th reinforced track cross ties from the bottom with the clamp on the 5th cross tie. Power drive should be on the underside of the track. Center the drive between the track rails and lock in place by rotating the lock to the left. Insert a #38 lock pin in the hole provided to prevent lock from loosening. Fasten the operating handles on the power drive. When facing the power drive from the rear or building side of the track, the power drive operator handles will be on your right. Details on power drive startup are given in Chapter 4.
5. Before reeving the hoist, inspect the wire rope for wear and damage. Detailed inspection procedures are in Chapter 6.



WARNING:

WEAR HEAVY LEATHER GLOVES WHEN HANDLING WIRE ROPE. INSUFFICIENT HAND PROTECTION WHEN HANDLING WIRE ROPE CAN CAUSE SERIOUS PERSONAL INJURY.



WARNING:

USING DEFECTIVE WIRE ROPE CAN CAUSE EQUIPMENT DAMAGE, SERIOUS PERSONAL INJURY, OR DEATH.

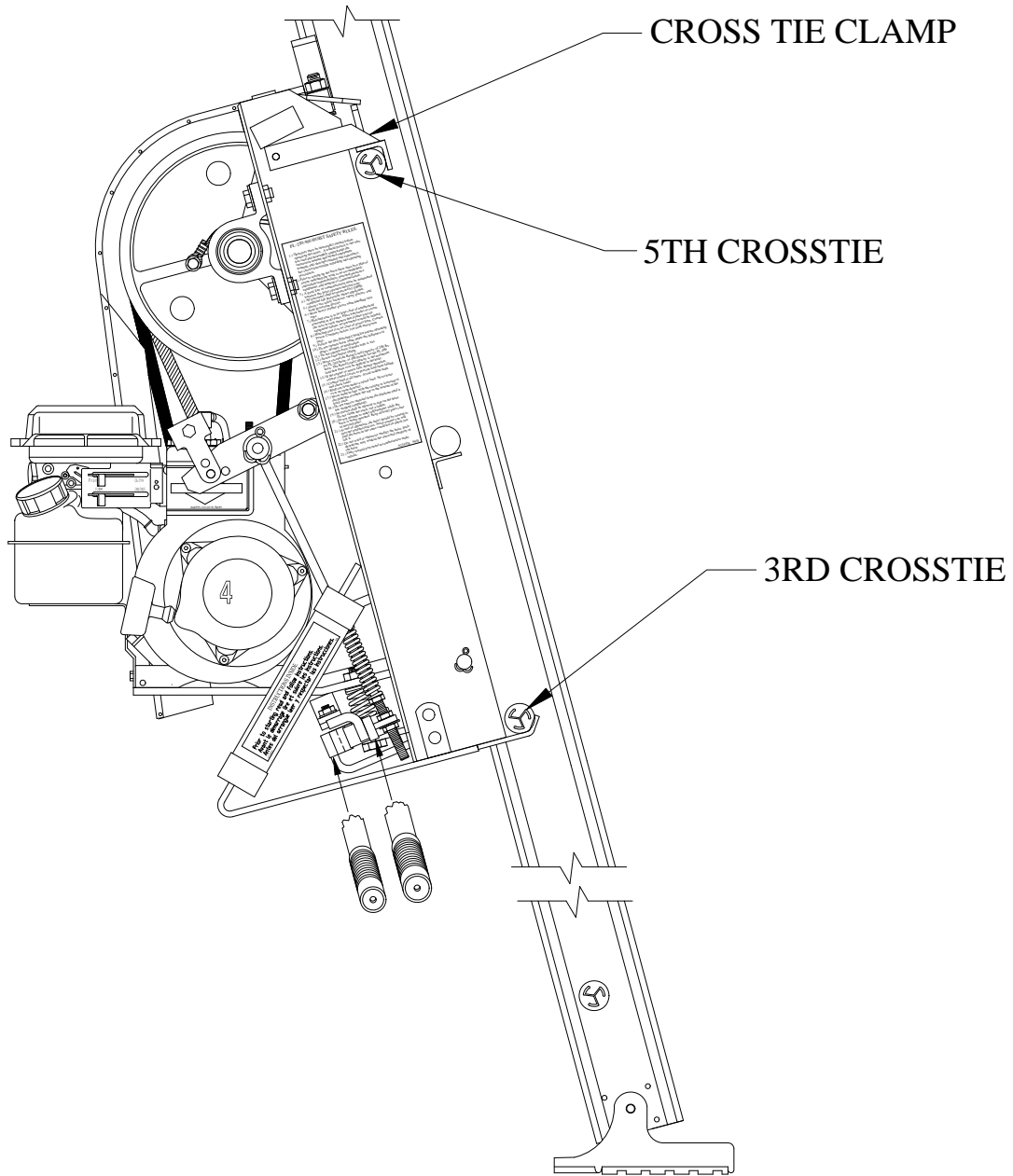

Figure 3-1.
Power Drive 250G Installation on Pro track

4 OPERATION

4.1 BEFORE OPERATING THE POWER DRIVE



WARNING:

A GOOD LINE OF COMMUNICATION MUST BE MAINTAINED BETWEEN THE HOIST OPERATOR AND THE ROOF CREW.

1. Only trained personnel shall operate this equipment. A trained person is one who has read and thoroughly understands this instruction manual and related equipment manuals and, through training and experience, has shown knowledge regarding the safe operational procedures.
2. Obey all safety labels provided on your power drive. These labels warn you of potential hazards that can cause serious injury. If a label comes off or becomes hard to read, contact Reimann & Georger Corporation for a replacement.
3. Follow the Pre-hoisting Checklist in the front of this manual before operating.
4. Never use the power drive or hoist structure to anchor lifelines, worker harnesses, or other attachments.
5. Always use safety footwear, safety glasses, and head protection devices.
6. Before lifting, ensure the safety latch on the hook is not supporting any load. Never hoist over an open doorway.



WARNING:

THE HOISTING OPERATION MUST BE CLEAR OF ALL ELECTRICAL LINES AND OBSTRUCTIONS TO PREVENT EQUIPMENT DAMAGE AND/OR SERIOUS PERSONAL INJURY. CONSULT POWER COMPANY BEFORE WORKING NEAR POWER LINES.

7. Hoisting area is to be kept clear of unauthorized personnel. Place barricades or secure the area in such a manner that if there were an equipment failure, no personnel would be injured.
8. Inspect wire rope for damage, wear, or unraveling. Replace as necessary.
9. Check all hooks and sheaves. Replace as necessary.

4.2 POWER DRIVE STARTUP

4.2.1 Gas Engine Startup

1. Handle fuel with care. It is highly flammable. Use approved fuel container. Fill tank outdoors in a well ventilated area on a bare surface. Make sure the gas caps on the engine and fuel can are properly tightened. Ensure the fuel storage area is at least 10 feet from the power drive before starting the engine. Never remove the fuel cap or add fuel to a running or hot engine. Let the engine cool 2 minutes before fueling.
2. Check oil level in both the crankcase and reducer. Always add oil with the power drive on the level. Follow manufacturer specifications on type and amount of oil to add. Refer to the manufacturer's instructions and to Chapter 6 of this manual.



CAUTION:

GASOLINE ENGINES ARE SHIPPED WITHOUT OIL IN THE CRANKCASE. ATTEMPTING TO RUN THE ENGINE WITHOUT FILLING THE CRANKCASE AND TOPPING OFF THE REDUCER WITH OIL WILL CAUSE SERIOUS ENGINE DAMAGE AND MAY VOID THE WARRANTY.

3. Check the engine air cleaner and air intake screen for dirt or obstruction. Clean as required.
4. Move choke control to choke or start position and move throttle to half throttle position to start a cold engine. Move choke control to run position slowly after engine starts and allow a warm up. The choke must be in the run position during normal operation or when starting a warm engine. Placing the throttle in the slow position before stopping the engine permits a cooling period.



WARNING:

DO NOT USE IN WET CONDITIONS.

4.2.2 RAISING AND LOWERING THE LOAD



WARNING:

SECURE THE LOAD BEFORE LIFTING.



WARNING:

DO NOT OPERATE HOIST WHEN BRAKE ROPE IS WET

1. Before operating the clutch and brake levers, install the provided lever handles using the provided spring locks. Install the #25 handle extension shown in Figure 8-1 on the clutch lever handle using the nut and bolt provided.
2. Make a few “dry runs” (no load), to test power drive, hoisting operation, and controls.



WARNING:

NEVER STAND IN-LINE WITH THE RAISING OR LOWERING OF THE PLATFORM AT EITHER THE TOP OR BOTTOM OF THE HOIST TRACK.

3. To raise the load, first advance the throttle to increase the engine speed. Then lift the left clutch handle slowly with a smooth upward motion. This automatically tightens the drive belt and releases the brake, permitting the platform to roll up the track.
4. When the platform reaches the top of the track, release the clutch lever. This action stops the platform and automatically applies the brake, which holds the load and platform. The load will now roll automatically off the platform onto the roller angle guide if you are using one.



WARNING:

KEEP OUT FROM UNDER A RAISED LOAD.



WARNING:

IF THE ENGINE FAILS DURING OPERATION, RELEASE CONTROL LEVERS TO PREVENT LOAD FROM FALLING.

5. Do not allow the platform to jam against the spring stops on the top bracket. The drive belt may jam in the drum sheave, preventing the lowering of the platform.



WARNING:

DO NOT REMOVE MATERIAL FROM THE HOIST UNTIL IT HAS STOPPED COMPLETELY.

6. Lift the brake lever slowly to lower platform to the ground. **Lowering speed for SAFE operation should not exceed 50 feet/minute.** Continue to decelerate the platform as it nears the ground to prevent damage to platform or track. **Do not allow the platform to strike the track shoes on reaching the bottom of the track.** If necessary, extra downward pressure on the brake lever can be applied to stop the load.



WARNING:

AVOID SUDDEN BRAKING WHEN HANDLING A LOAD.

7. Check the hoist periodically during operation. Do not attempt to make adjustments during operation.



WARNING:

KEEP ALL BODY PARTS CLEAR OF MOVING PARTS.

4.3 PREPARING POWER DRIVE FOR SHUTDOWN

At the end of operation, secure the equipment to prevent unauthorized use. **Never** assume you will find the equipment in the same condition that you left it. Proceed as follows:

1. Ensure that all lifting tension has been removed from the wire rope.
2. Shut off power drive and take necessary action to prevent its unauthorized use.
3. If the power drive is being permanently disassembled, at the end of a project for example, follow the detailed disassembly procedures in Chapter 5.

5 DISASSEMBLY

5.1 PRIOR TO DISASSEMBLY

1. Before disassembling the power drive, read and follow all the safety rules of this manual. Failure to do this can lead to equipment damage and/or serious personal injury.
2. Insure that the platform is not supporting any load before proceeding.
3. Before dismantling, attach a tie rope to hold the platform in position at the base of the track.
4. Insure the track is securely tied to the roof with a rope fastened to a cross tie or top bracket to prevent track from slipping.
5. Check carefully for proximity of power lines or other overhead obstructions.



WARNING:

NEVER CLIMB ON THE TRACK FOR ANY REASON. THIS CAN CAUSE SERIOUS PERSONAL INJURY OR DEATH.



WARNING:

WEAR HEAVY LEATHER GLOVES WHEN HANDLING WIRE ROPE. INSUFFICIENT HAND PROTECTION WHEN HANDLING WIRE ROPE CAN CAUSE SERIOUS PERSONAL INJURY.

1. Tie a safety line at least 5 feet long to the wire rope end to prevent any accidental drawing of the operator's hand into the power drive winch during rewinding.
2. Start the power drive and lift the clutch handle to rewind wire rope. Insure that the wire rope is rewinding evenly on the drum. As the wire rope end approaches the drum, handle the wire rope only by the safety line.
4. When the wire rope end reaches the drum, release the clutch handle, shut off the power drive and remove the safety line. Anchor the wire rope end on the drum with a light rope or tape.
5. Remove the operating handles from the power drive. Remove the lock pin from the hole provided and loosen the lock by rotating it to the right. Then remove the power drive from the cross ties.

6 INSPECTION AND MAINTENANCE

6.1 GENERAL MAINTENANCE RULES

1. Proper maintenance of the power drive and related equipment consists of adhering to all the guidelines given in this chapter and in the Pre-Hoisting Checklist in the front of this manual. Proper maintenance is required to maintain the system in good condition, which is defined as each part being free of rust or other corrosion, bends, breaks, or other defects.
2. Review and follow all the safety rules given in Chapter 1 before attempting any maintenance.
3. Only authorized personnel should be allowed in the maintenance area. Authorized personnel are the trained people as defined below and their supervision.
4. Repairs must be made only by trained personnel. A trained person is one who has read and thoroughly understands this instruction manual and related equipment manuals and, through training and experience, has shown knowledge regarding the safe operational procedures.



WARNING:

WEAR HEAVY LEATHER GLOVES WHEN HANDLING WIRE ROPE. INSUFFICIENT HAND PROTECTION WHEN HANDLING WIRE ROPE CAN CAUSE SERIOUS PERSONAL INJURY.

5. Do not weld or otherwise modify the power drive. Such alterations may weaken the structural integrity of the power drive and invalidate your warranty.



WARNING:

DURING ANY ERECTION, MAINTENANCE, OR REPAIR PROCEDURES, DO NOT ATTEMPT ANY HOISTING. THIS CAN CAUSE EQUIPMENT DAMAGE AND/OR SERIOUS PERSONAL INJURY.



WARNING:

EXCEPT FOR MAINTENANCE AND REPAIRS THAT CANNOT BE DONE OTHERWISE, SHUT DOWN AND LOCK OUT THE POWER DRIVE TO PREVENT ACCIDENTAL STARTUP.



WARNING:

NEVER CLIMB THE TRACK TO DO MAINTENANCE. THIS CAN LEAD TO SERIOUS PERSONAL INJURY.

6.2 INITIAL INSPECTION

Power drive assembly and disassembly, must be done by trained personnel only as defined in Section 6.1. Each time after setting up the hoist and before placing it in service, all parts of the hoist structure, power drive, and other equipment must be thoroughly inspected by trained personnel as described in the remainder of this chapter and related equipment manuals.

6.3 DAILY INSPECTION

It is important that all the maintenance procedures outlined in the Pre-Hoisting Checklist in the front of this manual be done daily. Details on inspecting the wire rope are given in Section 6.9. All broken, worn or defective parts must be repaired or replaced before startup.

6.4 CLUTCH-BRAKE ADJUSTMENT

The combination clutch and brake actions to raise rated loads with the clutch handle are adjusted at the factory. If field adjustments are needed, proceed as follows. Refer to Figure 6-1 for adjustment details.

1. The Dacron brake holds the load when the clutch lever is released. If the load drifts down, tighten the nut at the base of the #24 spring to compress this spring. This increases the initial load on the brake lever. Note that the #24 spring should be compressed to about $3 \frac{1}{8} \pm \frac{1}{16}$ inches with about $\frac{3}{8}$ inches movement on the bottom edge of the #8 brake differential.
2. Excessive tightening fully compresses the spring and the brake will not release. There should always be a $\frac{1}{32}$ inch gap between brake lever #3 and nuts "B" and "C". If this "play" in brake lever #3 is absent, you can flex the rod and break it.
3. If the load still drifts down move the brake rope end "D" from the outer hole to the inner hole on the #8 brake differential. As the Dacron brake wears, the brake lever may need adjusting to bring the lever up to its proper operating position. Alternate holes are provided in the brake rope ends for this purpose.
4. When properly adjusted, the brake will release before the #10 clutch spring is entirely compressed. Gap "A" is widened or narrowed by screwing or unscrewing, respectively, nuts "B" and "C". Make this adjustment carefully. If there is no gap "A", the brake will release before the clutch belt is tightened. This will cause a sudden jerking before the clutch belt is tightened, resulting in an overload on the hoist, wire rope, and track. The clutch can be engaged sooner to help avoid this overloading by tightening the top nut on the #10 clutch spring shown in Figure 8-1. The clutch spring is preset at the factory to a compressed height of $1 \frac{3}{4}$ inches.

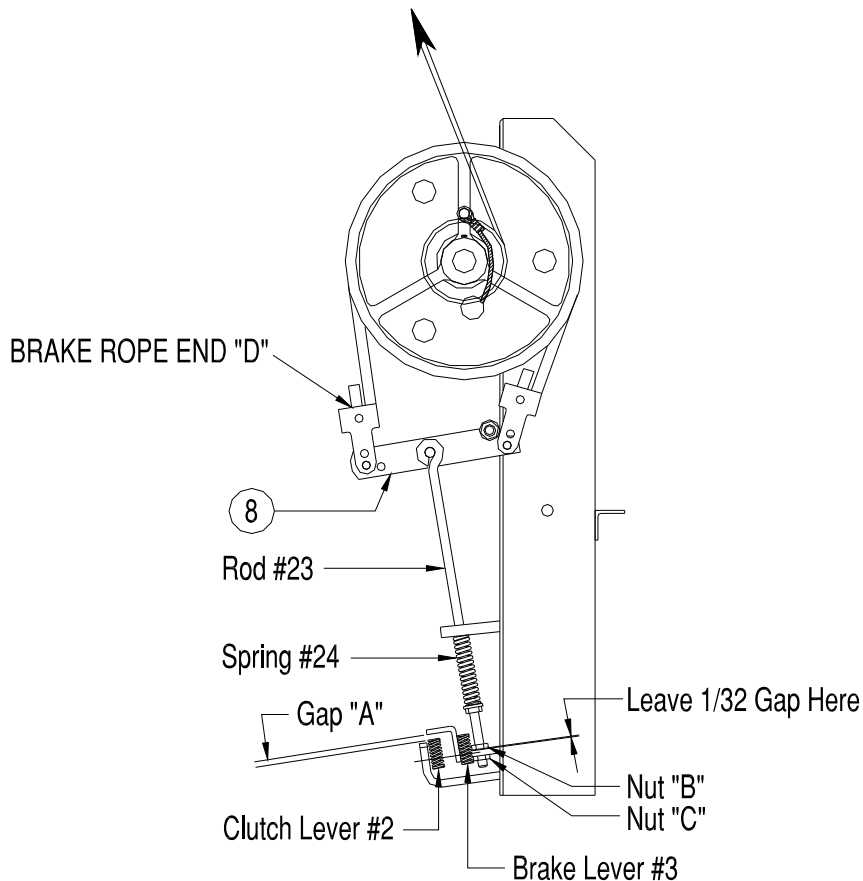

Figure 6-1.
Clutch-Brake Adjustment Detail

6.5 SAFETY HOOKS

The hook to which the power drive wire rope is attached will be either the platform safety hook on the PL250 & PRO200 models or the top bracket hook on the PL400 & PRO400 models. If these hooks should become broken, bent, or disassembled, they should be replaced immediately.

6.6 OILING MECHANICAL PARTS

The main bearings (shown as #18 in Figure 8-1) are lubricated for life and need no attention. Oil all pivots and linkage joints occasionally.

6.7 ENGINE OIL REQUIREMENTS



CAUTION:

GASOLINE ENGINES ARE SHIPPED WITHOUT OIL IN THE CRANKCASE. ATTEMPTING TO RUN THE ENGINE WITHOUT FILLING THE CRANKCASE AND REDUCER WITH OIL WILL CAUSE SERIOUS ENGINE DAMAGE AND MAY VOID THE WARRANTY.

6.7.1 Briggs & Stratton Engines

Before starting the engine, check and add oil according to the viscosity chart shown in your engine manual. Use a high quality detergent oil classified “For Service SF, SG, SH,” such as SAE 30 oil. Do NOT use special additives with recommended oils. Do NOT mix oil with gasoline.

Add oil and fill to overflowing as shown in your engine manual. Oil capacity is about 2/3 quart (21 ounces or 0.6 liter).

The gear reducer must also be filled with oil. To fill, pour SAE 30 oil into oil fill hole until it runs out the level check hole. Refer to the engine manual for details on filling the gear reducer.

After filling with or changing oil, start and run the engine at idle for 30 seconds. Shut engine off. Wait 30 seconds and check oil level.

The engine itself (**not** the power drive) must be in the upright (level) position when filling and checking oil.

6.8 ENGINE MAINTENANCE

The engine is guaranteed against defects by its manufacturer. Follow the manufacturer's instructions for proper lubrication and maintenance. The following table summarizes the type and frequency of maintenance required. Follow the hourly or calendar intervals, whichever occurs first. For repairs, contact the nearest authorized service center.

TYPE OF MAINTENANCE	FREQUENCY OF SERVICE
Check oil level	Every 5 hours or daily
Change oil	After first 5 hours, then after every 50 hours or every season. Change oil every 25 hours when operating under heavy load or in high temperatures.
Change oil in gear reduction	100 hours or every season
Service air cleaner pre-cleaner if equipped, or air cleaner cartridge if not equipped with pre-cleaner.	25 hours or every season. Clean more often under dusty conditions or when airborne debris is present. Replace air cleaner parts if very dirty.
Service air cleaner cartridge if equipped with pre-cleaner.	100 hours or every season. Clean more often under dusty conditions or when airborne debris is present. Replace air cleaner parts if very dirty.
Clean cooling system.	100 hours or every season. Clean more often under dusty conditions or when airborne debris is present. Replace air cleaner parts if very dirty.
Inspect spark arrester, if equipped.	50 hours or every season.
Replace or clean spark plug.	100 hours or every season.
Clean combustion chamber deposits.	100-300 hours.

6.9 WIRE ROPE INSPECTION PROCEDURE

Inspect the wire rope prior to each use and at least daily for signs of wear, damage, or pinching. Inspect the entire wire rope working length. Thoroughly inspect the rope sections that pass over sheaves or drums, or that make opposing turns. Inspect wire rope and end attachments carefully. While inspecting, examine sheaves, guards, guides, drums, flanges, and other surfaces contacting wire rope during operation. Correct any condition harming the rope in use or other damage or worn surfaces at this time.

Remove or replace immediately wire rope with one or more of the following defects:

1. Corrosion
2. Broken wires:
 - (a) One or more valley breaks. A valley break is a wire break occurring in the valley between two adjacent strands.
 - (b) Six randomly distributed broken wires in one rope lay. A rope lay is the length of rope along which one strand makes a complete revolution around the rope. See Figure 6-2. Keeping the rope clean and wound evenly on the drum will increase its life and efficiency.
3. Abrasion: Scrubbing, flattening or peening causing loss of more than one-third of the original diameter of the outside wires.
4. Kinking: Severe kinking, crushing, bird caging or other damage causing distortion of the rope structure. Bird caging is a bulging in the wire rope caused by the individual wires becoming untwisted. This untwisting of individual wires is usually caused by impact loading on the wire rope (such as a sudden stop).
5. Heat damage: Evidence of any heat damage caused by a torch or by contact with electrical wires.
6. Reduction of more than 1/64 inch from a nominal 5/16-inch or less diameter wire rope.

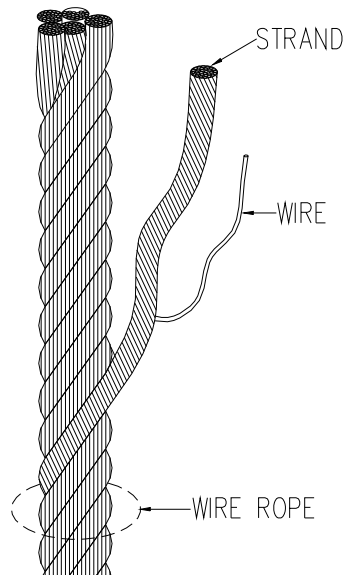

Figure 6-2.
Wire Rope Components

6.10 REPLACING POWER DRIVE WIRE ROPE

Each end of the hoist wire rope is equipped with loops. The small loop is attached to the #17 brake sheave (see Figure 6-3) by passing it through the hole and bending it back against the pull or load. It is snubbed over the web of the sheave and fastened to the sheave with the screw provided. The large loop is used for attaching loads with a shackle and hook. On platform units, the hook is mounted on the platform or top bracket, and the loop is slipped over the hook.

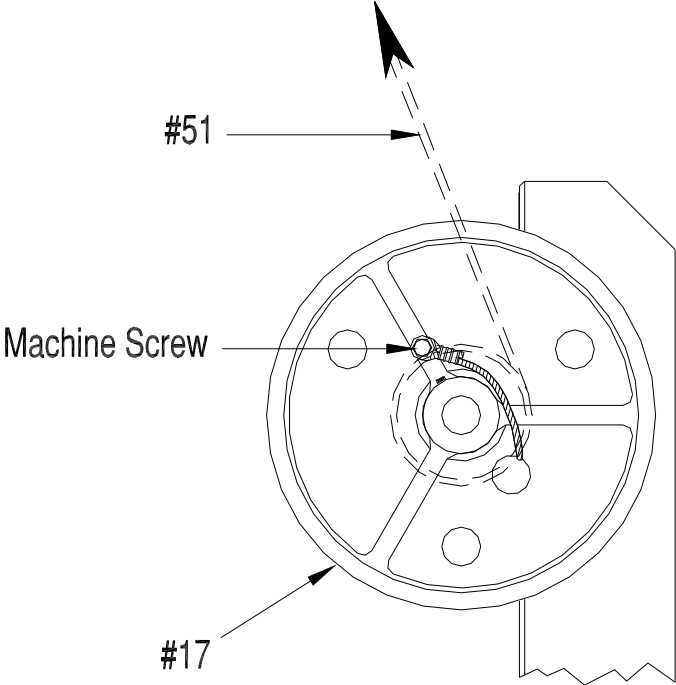

Figure 6-3.
Power Drive Wire Rope Installation on Brake Sheave

7 TROUBLESHOOTING

The following chart is intended to assist with troubleshooting the power drive. While not all inclusive, the chart outlines the most common causes of a problem and the recommended course of action.

The troubleshooting guide for the associated platform hoist is in the instruction manual specifically for that unit.

SYMPTOM	CAUSE AND CORRECTIVE ACTION
Gas engine will not start	<p>Air filter clogged—replace filter</p> <ol style="list-style-type: none"> 1. Too much oil in crankcase—pistons can't come back down which can saturate air filter with oil. 2. Tipping the engine, allowing oil to run up the relief tube. 3. Air filter dirty after normal use. <p>Clogged fuel line—replace fuel filter.</p> <p>Fuel shut off in OFF position—turn ON</p> <p>Engine switch in OFF position—turn ON</p>
Power Drive won't lift load or is lifting it very slowly.	<p>No oil in engine to build compression—must add oil. Check piston rings for compression.</p> <p>Hoist attempting to lift more than stated capacity of unit—check capacity rating and reduce load weight as needed</p> <p>Brake is dragging which may cause a “squealing” noise—adjust as described in Chapter 6.</p> <p>Clutch not properly adjusted—adjust as described in Chapter 6.</p> <p>Platform not moving freely—check for track obstructions or block and wire rope malfunctions</p> <p>Engine related problems—refer to beginning of this table. Reference to manufacturer's instruction manual may be necessary.</p> <p>Engine speed too slow—increase throttling.</p> <p>Too much wire rope on drum—hoisting capacity decreases as wire rope diameter increases.</p>
Engine stalls when clutch handle is lifted.	<p>Brake is releasing before clutch belt is tightened—close the gap by unscrewing nuts “B” and “C” to lower brake lever as described in Chapter 6.</p>
Power Drive will not lower platform.	<p>Platform has been allowed to jam against the spring stops on the top bracket causing the drive belt to jam in the drum sheave—shut off the gas engine. Then release the jammed belt by inserting a screw driver between the belt and the sheave groove.</p>
Load drifts down.	<p>Spring #24 as shown in Figure 6-1 needs compressing—tighten the nut as described in Chapter 6.</p> <p>Brake rope end “D” needs adjusting—move from the outer hole to the inner hole on the brake differential.</p>

8 PARTS LISTS

Each item number on the following parts lists can be matched with the item number shown on the corresponding assembly drawing as indicated below.

8.1 250G POWER DRIVE

Refer to Figure 8-1.

Item Number	Part Number	Quantity	Description
1	0400702	1	FRAME
2	0404402	1	CLUTCH LEVER
2A	0404403	1	CLUTCH HANDLE
3	0404404	1	BRAKE LEVER
3A	0404405	1	BRAKE HANDLE W/ GRIP & DECAL
4	0413446	1	ENGINE PLATE
5	0404407	1	PIVOT SHAFT
6	0404525	1	CROSS TIE CLAMP
7	0402225	1	CROSS TIE LOCK
8	0404410	1	BRAKE DIFFERENTIAL
9	0404411	1	SHAFT
10	5800149	1	SPRING
11	0404423	1	BELT GUIDE
12	5804005	1	PIN
13	0462801	1	BRAKE ROPE
16	6400654	1	HANDLE GRIP 7/8"
17	7300611	1	BRAKE SHEAVE 10"
18	5100718	2	BEARING PB100 X 1
19	6700719	1	V BELT B56
20	0400720	1	SHEAVE & DRUM (LESS BRAKE SHEAVE)
21	5800131	1	SPRING
22	5800136	1	SPRING
23	0400739	1	BOLT EYE
24	5800661	1	SPRING
25	0404414	1	HANDLE EXTENSION W/ GRIP & DECAL
26	0413083	1	ENGINE GAS 4 HP
32	7300732	1	SHEAVE BK52 X 3/4
37	0405419	1	GUARD
38	5800138	3	SPRING & LOCK PIN
44	6400143	1	HANDLE GRIP 1"
51	7304300	1	WIRE ROPE 5/32"

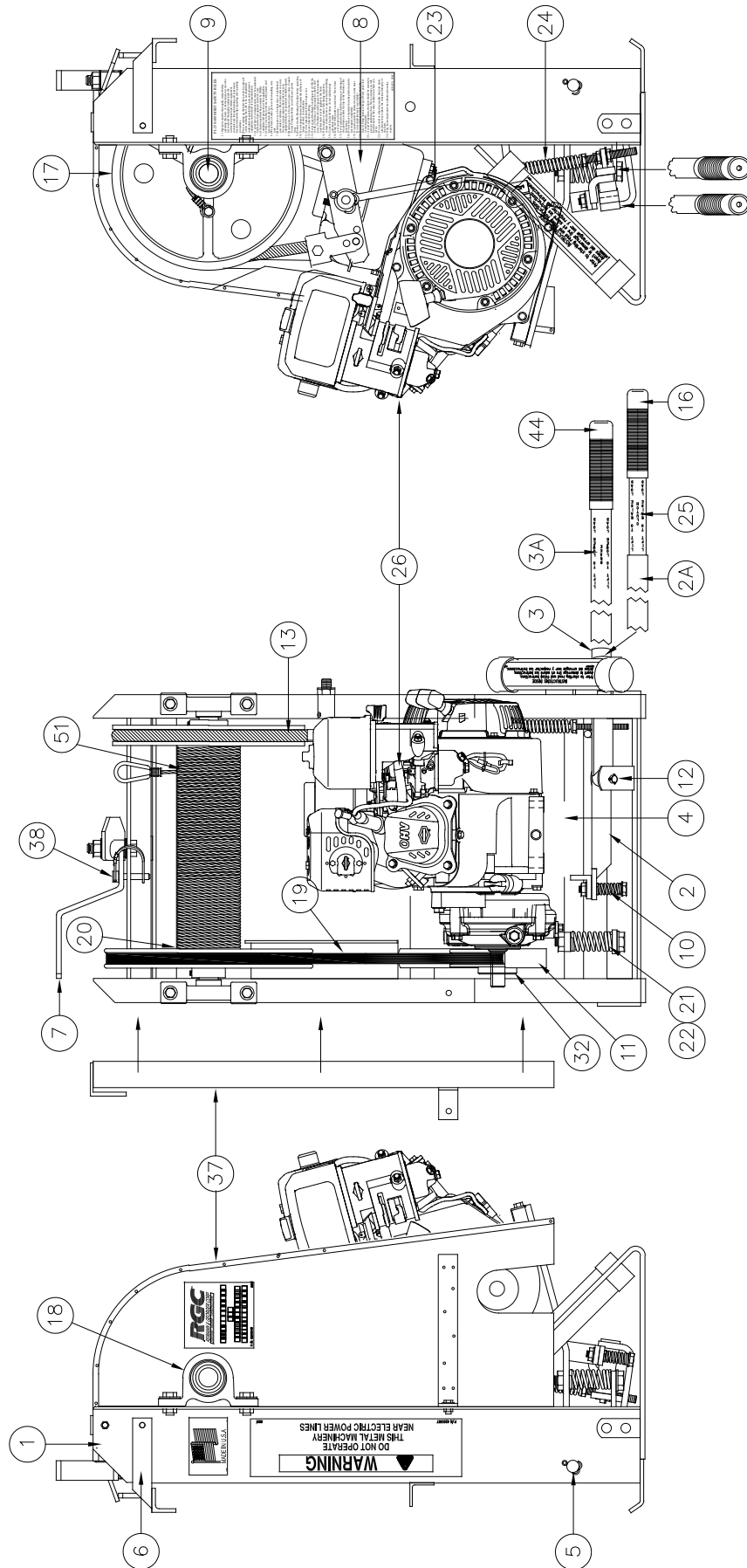

Figure 8-1.
250G Power Drive Assembly Drawing

LIMITED PRODUCT WARRANTY

**Reimann & Georger Corporation
Hoisting and Construction Products**

A. LIMITED WARRANTY

Reimann & Georger Corporation (the “Manufacturer”) warrants to the original purchaser (the “Buyer”) that all Reimann & Georger Hoisting and Construction products shall be free of defects in material and workmanship for a period of one (1) year from date of original purchase.

B. MANUFACTURER’S OBLIGATIONS

The Manufacturer’s sole obligation under this Limited Warranty is the repair or, at the Manufacturer’s discretion, the replacement of parts found to be defective. Parts and equipment must have authorization from the Manufacturer prior to return to the Manufacturer or repair by an authorized service person. Costs of transportation and other expenses connected with replacing or repairing parts are not covered under this Limited Warranty.

C. PARTS MANUFACTURED BY OTHERS

This Limited Warranty does not cover any parts manufactured by others. Such parts are subject to the warranty, if any, of their respective manufacturers, and are to be repaired only by a respective authorized service person for such parts. The Manufacturer shall have no obligation to undertake repairs of parts manufactured by others.

D. NO SPECIAL, INCIDENTAL, OR CONSEQUENTIAL DAMAGES

IN NO EVENT SHALL THE MANUFACTURER BE LIABLE TO THE BUYER OR ANY OTHER PERSON FOR ANY INDIRECT, SPECIAL, INCIDENTAL OR CONSEQUENTIAL LOSSES OR DAMAGES CONNECTED WITH THE USE OF THE PRODUCT UNDER THIS LIMITED WARRANTY. SUCH DAMAGES FOR WHICH THE MANUFACTURER SHALL NOT BE RESPONSIBLE INCLUDE, BUT ARE NOT LIMITED TO, LOST TIME AND CONVENIENCE, LOSS OF USE OF THE PRODUCT, THE COST OF A PRODUCT RENTAL, COSTS OF GASOLINE, TELEPHONE, TRAVEL, OR LODGING, THE LOSS OF PERSONAL OR COMMERCIAL PROPERTY, AND THE LOSS OF REVENUE.

E. NO LIABILITY IN EXCESS OF PURCHASE PRICE

IN NO EVENT SHALL THE MANUFACTURER’S OBLIGATIONS UNDER THIS LIMITED WARRANTY EXCEED THE PURCHASE PRICE OF THE PRODUCT.

F. NO EXTENSION OF STATUTE OF LIMITATIONS

ANY REPAIRS PERFORMED UNDER THIS WARRANTY SHALL NOT IN ANY WAY EXTEND THE STATUTES OF LIMITATIONS FOR CLAIMS UNDER THIS LIMITED WARRANTY.

G. WAIVER OF OTHER WARRANTIES

THE EXPRESS WARRANTIES SET FORTH IN THIS LIMITED WARRANTY ARE IN LIEU OF AND EXCLUDE ANY AND ALL OTHER WARRANTIES, EXPRESS OR IMPLIED, INCLUDING, BUT NOT LIMITED TO, THE IMPLIED WARRANTIES OR MERCHANTABILITY AND FITNESS FOR A PARTICULAR PURPOSE.

H. PROCEDURE FOR WARRANTY PERFORMANCE

If the product fails to perform to the Manufacturer’s specifications, the Buyer must provide the Manufacturer with the applicable model and serial numbers, the date of purchase, and the nature of the problem.

I. ADDITIONAL EXCLUSIONS FROM THIS LIMITED WARRANTY. THIS LIMITED WARRANTY DOES NOT COVER ANY OF THE FOLLOWING:

1. Equipment which has been abused, damaged, used beyond rated capacity, or repaired by persons other than authorized service personnel.
2. Damage caused by acts of God which include, but are not limited to, hailstorms, windstorms, tornadoes, sandstorms, lightning, floods, and earthquakes.
3. Damage under conditions caused by fire or accident, by abuse or by negligence of the user or any other person other than the Manufacturer, by improper installation, by misuse, by incorrect operation, by "normal wear and tear", by improper adjustment or alteration, by alterations not completed by authorized service personnel, or by failure of product parts from such alterations.
4. Costs of repairing damage caused by poor or improper maintenance, costs of normally scheduled maintenance, or the cost of replacing any parts unless done as the result of an authorized repair covered by the one (1) year Limited Warranty.
5. Costs of modifying the product in any way once delivered to the Buyer, even if such modifications were added as a production change on other products made after the Buyer's product was built.

J. NO AUTHORITY TO ALTER THIS LIMITED WARRANTY

No agent, representative, or distributor of the Manufacturer has any authority to alter the terms of this Limited Warranty in any way.