



# PRO200 PLATFORM HOIST INSTRUCTIONS

**OBSOLETE**

REIMANN & GEORGER CORPORATION  
HOISTING PRODUCTS  
P/N 6102078-A

BUFFALO, NY  
8/29/03

## PRE-HOISTING CHECKLIST

This checklist must be checked prior to each use of the hoist. This checklist is to be used as a guideline in conjunction with the maintenance and inspection procedures outlined in this manual. The hoist and related equipment must be thoroughly inspected prior to each use by a trained person. A trained person is one who has read and thoroughly understands this instruction manual and related equipment manuals and, through training and experience, has shown knowledge regarding the safe operational procedures. If you do not have such a person in your organization, please contact Reimann & Georger Corporation or its distributors and they will assist you in providing such a "trained person". Do not permit any person who is not fully trained to operate this platform hoist. It is recommended that this checklist be maintained as a permanent record.

- Discuss work plan, personal protective equipment, and each crew member's responsibility before starting to set-up.
- Insure OSHA compliant fall protection is in place.
- Insure hoisting operation will clear all power lines and obstructions.
- Insure hoisting area is secured from all unauthorized personnel.
- Insure the track is securely tied to the roof to prevent track from slipping.
- Insure that both track shoes are resting on a firm level surface and both wheels are 3/8" off surface to prevent track slippage or uneven loading.
- Insure the load does not exceed the rated load capacity of the hoist model being used.
- Insure all structural members of the hoist are free of defects and damage that may affect the integrity of the hoist.
- Insure brake rope is not wet.
- Inspect wire rope for signs of wear and damage. Replace defective wire rope immediately.
- Insure that at least three wraps of wire rope are on the winch drum at maximum travel.
- Insure that the screw securing wire rope end loop to the brake sheave is tight and in good condition.
- Insure wire rope is reeved properly for (1) part of line for the PRO200 hoist.
- Insure that track support has been properly installed for track lengths over 28 feet.
- Insure that the bottom of the track is away from the building 1/4 of the supported height plus the building overhang.
- Insure that all bolts and nuts are tightened securely.
- Insure all sheaves can rotate freely.
- Insure safety latch on the hook does not support any load.
- Insure power drive has been properly maintained.
- Operate hoist with no load to test hoisting operation, controls, and power drive.

**INSPECTOR:** \_\_\_\_\_ **DATE:** \_\_\_\_\_

## TABLE OF CONTENTS

CHAPTER	DESCRIPTION	PAGE
<b>1</b>	<b>SAFETY .....</b>	<b>1</b>
1.1	Introduction .....	1
1.2	Safety Definitions .....	1
1.3	PRO200 Platform Hoist Safety Labels .....	1
1.4	PRO200 Platform Hoist Safety Rules.....	1
<b>2</b>	<b>SPECIFICATIONS .....</b>	<b>3</b>
2.1	PRO200 Platform Hoist Specifications .....	3
2.2	Complete System Specifications .....	3
2.3	Nameplate and Serial Number Tag.....	3
<b>3</b>	<b>INSTALLATION AND SETUP .....</b>	<b>4</b>
3.1	Prior to Setup.....	4
3.2	Completing the Platform Assembly.....	4
3.3	Mounting the Platform on the Track .....	6
3.4	Assembling the Track Sections .....	7
3.5	Mounting the Top Bracket.....	7
3.6	Raising the Track.....	7
3.6.1	Procedure A .....	7
3.6.2	Procedure B .....	8
3.7	Installing Track Support.....	9
<b>4</b>	<b>OPERATION.....</b>	<b>10</b>
4.1	Before Operating the Platform Hoist.....	10
4.2	Raising and Lowering the Load .....	10
4.3	Preparing Platform Hoist for Shutdown .....	11
<b>5</b>	<b>DISASSEMBLY .....</b>	<b>12</b>
5.1	Prior to Disassembly.....	12
5.2	Removing Track Support .....	12
5.3	Lower the Track .....	12
5.4	Disassembling the Track Sections .....	13
<b>6</b>	<b>INSPECTION AND MAINTENANCE .....</b>	<b>14</b>
6.1	General Maintenance Rules.....	14
6.2	Initial Inspection.....	14
6.3	Daily Inspection.....	14
6.4	Safety Hooks .....	15
6.5	Wire Rope Inspection Procedure.....	15
<b>7</b>	<b>TROUBLESHOOTING .....</b>	<b>16</b>
<b>8</b>	<b>PARTS LISTS.....</b>	<b>17</b>

## LIST OF FIGURES

FIGURE	DESCRIPTION	PAGE
2-1	PRO200 Platform Hoist Product Nameplate .....	3
3-1	Platform Flipper Assembly .....	4
3-2	Platform Brace Sub-Assembly .....	5
3-3	Platform and Brace Assembly .....	5
3-4	Platform Assembly – Complete .....	6
3-5	Bottom Track Section .....	6
3-6	Track Support Assembly .....	9
6-1	Wire Rope Components .....	15
8-1	Platform Hoist Assembly Drawing .....	18

## LIST OF TABLES

TABLE	TITLE	PAGE
3-1	Track Support Location Requirements .....	9

# 1 SAFETY

## 1.1 INTRODUCTION

Your Reimann & Georger Corporation PRO200 Platform Hoist has been engineered to provide lifting performance, long term economics and safety advantages that no other type can match. However, even a well-designed and well-built hoist can malfunction or become hazardous in the hands of an inexperienced and/or untrained user. Therefore, read this manual and related equipment manuals thoroughly before operating your hoist to provide maximum safety for all operating personnel, and to get the maximum benefit from your equipment.

## 1.2 SAFETY DEFINITIONS

A safety message alerts you to potential hazards that could injure you or others or cause property damage. The safety messages or signal words for product safety signs are **DANGER**, **WARNING**, and **CAUTION**. Each safety message is preceded by a safety alert symbol and is defined as follows:

**DANGER:** Indicates an imminently hazardous situation which, if not avoided, **will** cause death or serious injury. This safety message is limited to the most extreme situations.

**WARNING:** Indicates a potentially hazardous situation which, if not avoided, **could** result in death or serious injury.

**CAUTION:** Indicates a potentially hazardous situation which, if not avoided, **may** result in minor or moderate injury. It may also be used to alert against unsafe practices and property-damage-only accidents.

## 1.3 PRO200 PLATFORM HOIST SAFETY LABELS

These labels warn you of potential hazards that could cause injury. Read them carefully. If a label comes off or becomes illegible, contact Reimann & Georger Corporation for a free replacement.

## 1.4 PRO200 HOIST SAFETY RULES

1. Operators must be trained before operating this hoist. A trained person is one who has read and thoroughly understands this instruction manual and related equipment manuals and, through training and experience, has shown knowledge regarding the safe operational procedures.
2. Prior to setting up the hoist there must be a plan of action outlining the work to be accomplished, individual responsibilities, personal protective equipment, and method of communication.
3. All personnel shall be protected by OSHA compliant fall protection where applicable.
4. Never use the hoist structure to anchor life lines, worker's harnesses or other attachments.
5. **Always** use safety footwear, safety glasses, and head protection devices.
6. A good line of communication must be maintained between the hoist operator and the roof crew.
7. Hoisting area is to be kept clear of unauthorized personnel at all times. Place barricades or secure the area in such a manner that if there were an equipment failure, no personnel would be injured.
8. Hoisting area is to be clear of power lines. Consult Power Company before you work near power lines.
9. Follow the Pre-Hoisting Checklist before operating.
10. Wear heavy leather gloves when handling wire rope.
11. Secure load before lifting.

12. Do not remove material from the platform until it has stopped completely.
13. Keep out from under a raised load.
14. Never stand in-line with the raising or lowering of the platform at either the top or bottom of the hoist track.
15. Never hoist over an open doorway.
16. Never exceed the Rated Load Capacity of 200 pounds for the PRO200 hoist. The Rated Load Capacity is the maximum load that should ever be applied to the hoist.
17. Avoid sudden stops and shock loads.
18. No person shall be allowed to ride on the hoist.
19. NEVER climb the track; use a ladder.
20. Check the hoist periodically during operation. Know how to stop the power drive quickly in case of emergency.
21. Do not attempt to make adjustments while the hoist is being operated.
22. If the engine or motor fails during operation, release control levers to prevent load from falling.
23. Keep all body parts clear of moving parts.
24. Do not operate hoist when brake rope is wet.
25. Do not operate hoist when under the influence of drugs, alcohol, or medication.
26. At end of operation, the hoist should be secured to prevent unauthorized use. Never assume you will find the hoist in the same condition in which you left it.
27. Do not weld or otherwise modify the hoist. Such alterations may weaken the structural integrity of the hoist.
28. Only trained personnel are authorized to do repairs.

## 2 SPECIFICATIONS

### 2.1 HOIST SPECIFICATIONS

	<b>MODEL</b> <b>PRO200</b>
Load capacity	200 lbs.
Lift speed	220 fpm
Platform size	13 in. x 17 in.
Track (3 3/4" side rail)	17 in. width
Wire rope	5/32-in. diameter, 7 x 19 galvanized aircraft wire rope

Note that platform speeds and capacities are average and are based on 5/32 inch wire rope diameter. As wire rope builds up on drum, lifting speed increases and lifting capacity decreases in direct proportion to drum diameter.

### 2.2 COMPLETE SYSTEM SPECIFICATIONS

16 foot: Includes PRO Drive, Platform assembly, 16-foot aluminum Track with shoes.

28 foot: Includes PRO Drive, Platform assembly, 16-foot aluminum Track with shoes, additional 8 foot and 4 foot Track sections with splice plates.

44 foot: Includes PRO Drive, Platform assembly, 16 foot aluminum Track with shoes, additional 16 foot, 8 foot, and 4 foot track sections with splice plates, Telescoping track support.

### 2.3 NAMEPLATE AND SERIAL NUMBER TAG

It is important to identify your hoist completely and accurately whenever ordering spare parts or requesting assistance in service. The platform hoist nameplate is located on the platform main frame. The label shows the model number, serial number and the capacity rating. The platform hoist label should appear as the sample nameplate shown in Figure 2-1. Record the model and serial numbers, and capacity rating for future reference.

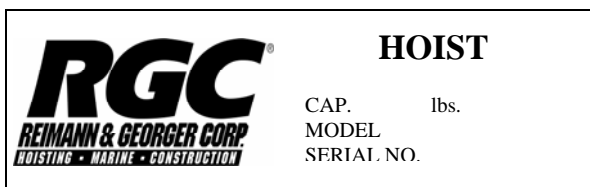

**Figure 2-1.**  
**PRO200 Platform Hoist Product Nameplate**

**MODEL** \_\_\_\_\_

**SERIAL NUMBER** \_\_\_\_\_

**CAPACITY RATING** \_\_\_\_\_

### 3 INSTALLATION AND SETUP

#### 3.1 PRIOR TO SETUP

1. Insure all structural members of the hoist are free of defects and damage that may affect the integrity of the unit.
2. Insure the hoisting area is secured from all unauthorized personnel.



**WARNING:**  
INSURE THAT OSHA COMPLIANT FALL PROTECTION IS IN PLACE.



**WARNING:**  
PRIOR TO SETTING UP THE HOIST THERE MUST BE A PLAN OF ACTION OUTLINING THE WORK TO BE ACCOMPLISHED, INDIVIDUAL RESPONSIBILITIES, PERSONAL PROTECTIVE EQUIPMENT, AND THE METHOD OF COMMUNICATION. FAILURE TO DO THIS CAN RESULT IN DEATH, SERIOUS PERSONAL INJURY OR EQUIPMENT FAILURE.



**WARNING:**  
INSURE THAT ALL BOLTS AND NUTS ARE TIGHTENED SECURELY TO PREVENT EQUIPMENT DAMAGE AND/OR SERIOUS INJURY.

#### 3.2 COMPLETING THE PLATFORM ASSEMBLY

1. Refer to Figure 3-1. Secure guide roller to platform flipper using hex head bolts, washers and locknuts. Tighten bolts securely.

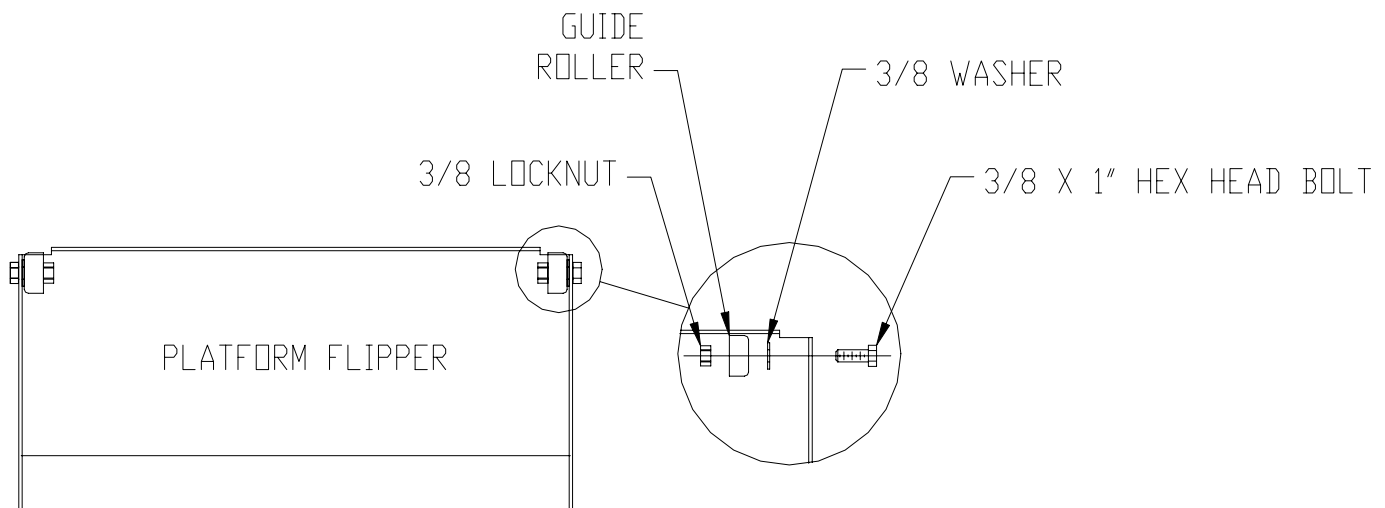

**Figure 3-1.**  
**Platform Flipper Assembly**

2. Refer to Figure 3-2. Position platform right brace inside frame with tie down holes at top. Align the three lower holes in main frame with three holes in brace. Secure in place using three 1/4 x 3/4" long hex head bolts and locknuts. Hand tighten only.
3. Repeat step 2 using left brace.



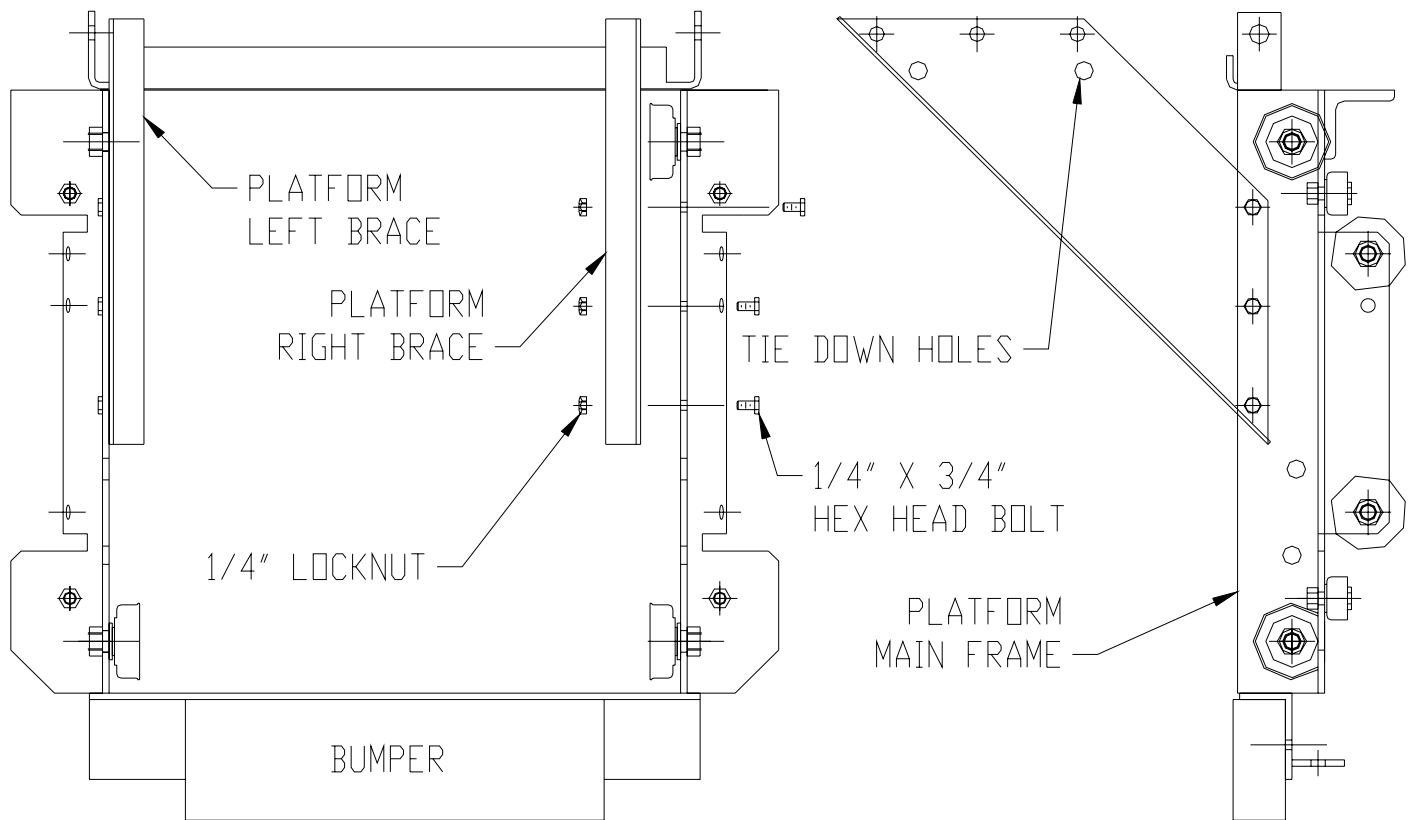

**Figure 3-2.**  
**Platform Brace Sub-Assembly**

4. Refer to Figure 3-3. Position platform top so the six mounting holes align with the six mounting holes of the right and left braces. Secure in place using six 1/4 x 3/4" long hex head bolts and locknuts. Hand tighten.

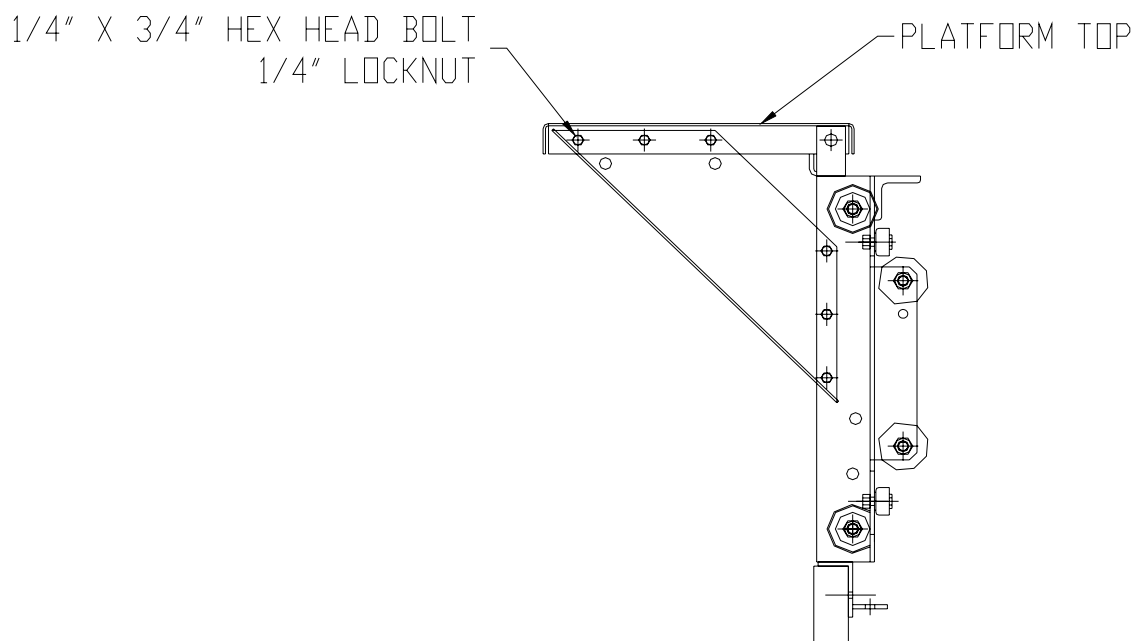

**Figure 3-3.**  
**Platform and Brace Assembly**

1. Refer to Figure 3-4. Align the platform flipper mounting tabs in between the main frame and platform top. Insert a 3/8 x 1" long hex head bolt through the main frame and assemble a 3/8" washer, the flipper and platform as shown. Repeat the procedure on the opposite side and secure with locknuts. Do not over tighten, as the platform flipper must rotate freely.
2. Securely tighten the twelve 1/4 x 3/4" long hex head bolts.

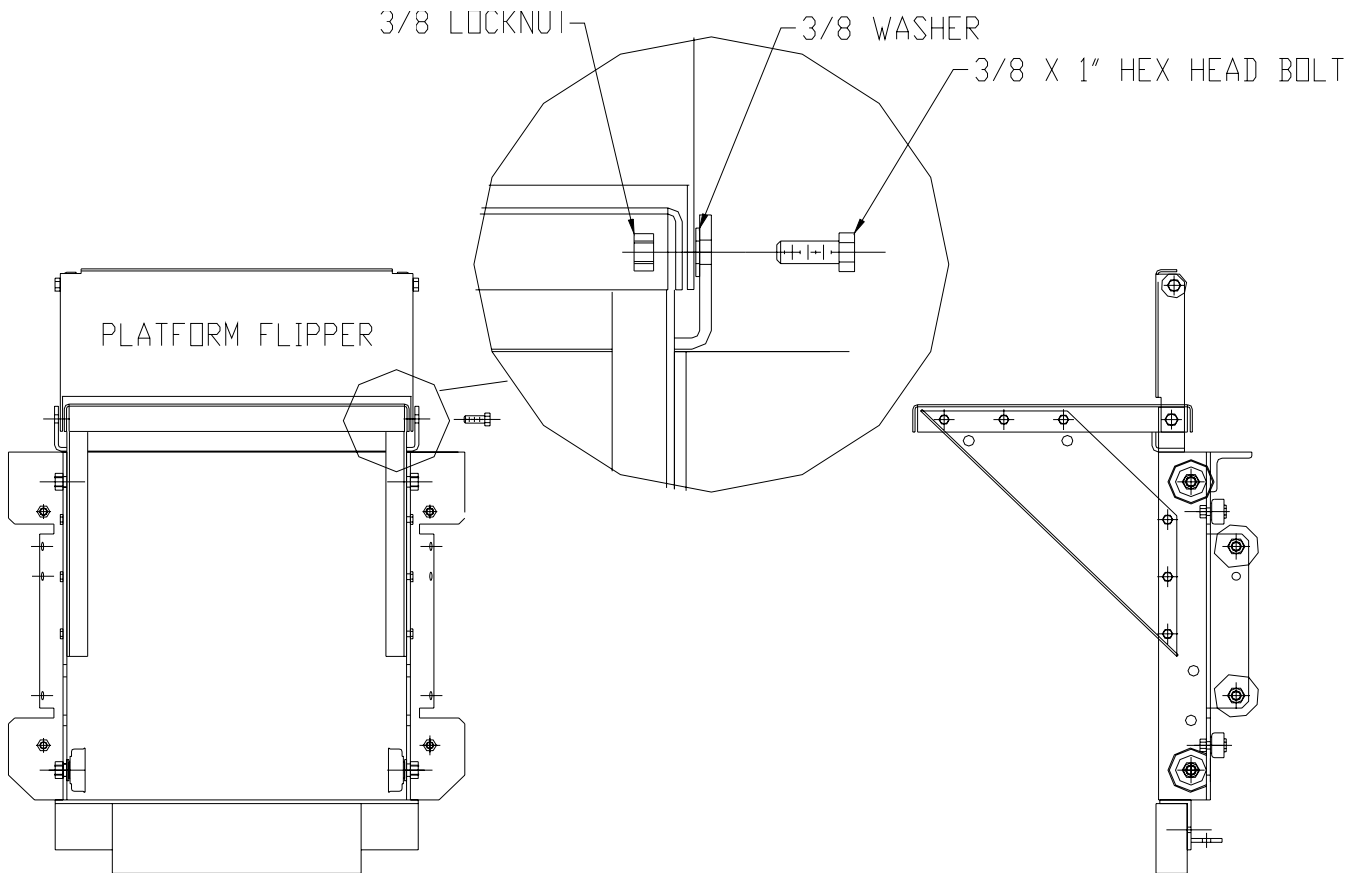

**Figure 3-4.**  
**Platform Assembly - Complete**

### 3.3 MOUNTING THE PLATFORM ON THE TRACK

1. Refer to Figure 3-5. The track cross ties are offset from the center of the rails to allow passage of the platform wheels. Before erecting the track, lay the bottom 16-foot track section on the ground with the track shoes as shown with the greater cross tie offset on top (2-1/4").

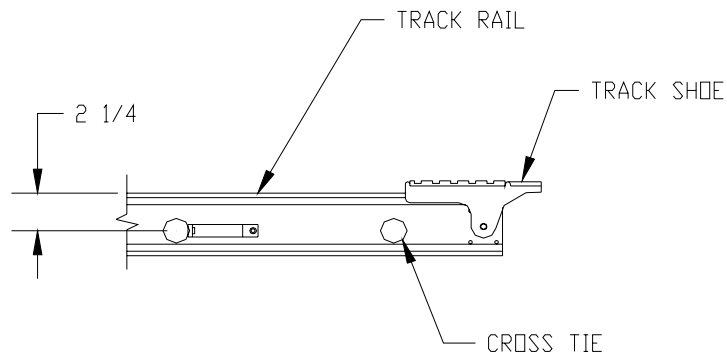

**Figure 3-5.**  
**Bottom Track Section**

2. The assembled platform slides onto the rails from the end of the track section opposite the shoes. The wooden platform bumper should face the shoes. Roll the platform down the track without striking the shoes and securely tie it to any cross tie to prevent movement when raising the track.
3. When mounting the platform on the track, check the following:
  - A) All four wheels should contact the top of the rails with application of light pressure.
  - B) Make sure the wooden bumper is not split. Do **NOT** remove the bumper.

### 3.4 ASSEMBLING THE TRACK SECTIONS

The standard sectional platform hoist consists of three sections of track: a 16 foot bottom section with shoes, an 8 foot and a 4 foot section, both with splice plates bolted permanently to their bottom end. These sections may be joined together with their splice plates by sliding the bottom of one section into the top of the lower section and installing the hex nuts and bolts provided. Tracks of 16 feet, 20 feet, 24 feet, and 28 feet can be assembled as desired from these three sections. Select a length that allows the top of the assembled rail to project 2 to 2-1/2 feet above the edge of roof.

For longer track lengths, a 16 foot center section with splice plates attached is available to provide tracks up to 44 feet. Lengths over 28 feet require a Track Support for additional support for these long tracks. Installation instructions for the Track Support are in Section 3.7. All bolts and nuts must be tightened securely to prevent track failure under load.

### 3.5 MOUNTING THE TOP BRACKET

Slide the top bracket into the end of the top track section, aligning the mounting holes on the top bracket with those on the track. Bolt securely to the track using the four 3/8 x 3/4" carriage bolts and four 3/8" wing nuts provided. The track is now ready to be raised to its operating position.

### 3.6 RAISING THE TRACK



**WARNING:**  
**THE HOISTING OPERATION MUST BE CLEAR OF ALL ELECTRICAL LINES AND OBSTRUCTIONS TO PREVENT EQUIPMENT DAMAGE AND/OR SERIOUS PERSONAL INJURY. CONSULT POWER COMPANY BEFORE WORKING NEAR POWER LINES.**

Two methods are suggested for raising the track to its operating position. Refer to either Section 3.6.1 or 3.6.2.

#### 3.6.1 Procedure A

1. Insure a tie rope is holding the platform in position at the base of the track. Lay the assembled track with platform and top bracket attached parallel to the building wall that is to support the track.
2. Use a person on the roof to lower a tether rope from the roof. Attach the tether rope to the top bracket to pull up the track with a person on the ground with their feet braced against the track shoes. This keeps the bottom of the track from slipping. The person on the ground also aids in raising the track by pulling against the rails, cross ties, or platform.
3. Another person on the ground may aid in erecting by "walking" the track up hand over hand on the rails or cross ties. When the track reaches a vertical position, carefully turn the track 90° with the platform away from the building. Move the bottom of the track away from the building 1/4 of the height of the building where the track is to be supported. Allowance must be made for an overhang on the building. See Table 3-1 in Section 3.7 for approximate distances of base of track from building.
4. Securely tie the track to the roof with a rope fastened to a cross tie or top bracket to prevent track from slipping.



**WARNING:**

**NEVER CLIMB ON THE TRACK. THIS CAN CAUSE SERIOUS PERSONAL INJURY OR DEATH. USE A LADDER.**

5. Position the PRO Drive on the 1<sup>st</sup>, 2<sup>nd</sup> and 3<sup>rd</sup> cross ties from the bottom with the cross tie clamp on the 3<sup>rd</sup> cross tie. Note that the 2<sup>nd</sup> and 3<sup>rd</sup> cross ties are reinforced. The PRO Drive should be on the underside of the track. Center the PRO Drive between the track rails and lock in place by rotating the cross tie lock to the left. Insert the lock pin in the hole provided to prevent lock from loosening. Fasten the operator handle to the PRO Drive lever. When facing the PRO Drive from the rear or building side of the track, the PRO Drive handle is on your left. Refer to the PRO Drive instruction manual for startup and operating information. The top of the PRO Drive should be level, with a 3/8” clearance under both wheels when set up properly. The engine may not operate correctly if it is not level.
6. Before reeving the hoist, inspect the wire rope for wear and damage. Detailed inspection procedures are in Chapter 6.



**WARNING:**

**WEAR HEAVY LEATHER GLOVES WHEN HANDLING WIRE ROPE. INSUFFICIENT HAND PROTECTION WHEN HANDLING WIRE ROPE CAN CAUSE SERIOUS PERSONAL INJURY.**



**WARNING:**

**USING DEFECTIVE WIRE ROPE CAN CAUSE EQUIPMENT DAMAGE, SERIOUS PERSONAL INJURY, OR DEATH.**

7. To reeve the hoist, tie a tether rope, lowered from the roof, to the wire rope end and with the brake released, pull the hoist wire rope to the roof on the underside of the track. Remove the tether rope. Reeve wire rope through the sheave on the top bracket. Reattach tether rope and pull the wire rope to the ground on the platform side of the track. Remove tether rope and fasten wire rope to the hook provided on the platform main frame. This is single line operation. The winding drum must not have less than three turns of rope when the platform is at the lowest point of travel. Insure that the sheaves rotate freely.
8. Remove the tie rope holding platform in position on the track.



**WARNING:**

**MAKE SURE THAT BOTH TRACK SHOES ARE RESTING ON A FIRM, LEVEL SURFACE. THIS PREVENTS TRACK SLIPPAGE OR UNEVEN LOADING OF TRACK WHICH CAN CAUSE EQUIPMENT DAMAGE OR PERSONAL INJURY.**

**3.6.2 Procedure B**

1. Insure a tie rope is holding the platform in position at the base of the track. Place track perpendicular to the building with the bottom of the shoes resting against the building to prevent slipping.
2. Use a person on the roof to lower a tether rope from the roof. Attach the tether rope to the top bracket to pull up the track with a person on the ground with their feet braced against the track shoes. A person on the ground may aid in erecting by “walking” up the track hand over hand on the rails or cross ties.
3. When the track reaches a vertical position, carefully turn the track 180° with platform away from building. Move the bottom of the track away from the building 1/4 of the height of the building where the track is to be supported. Allowance must be made for an overhang on building. See Table 3-1 in Section 3.7 for approximate distances of base of track from building.
4. Perform Steps 4 through 8 described in Section 3.6.1, Procedure A.

### 3.7 INSTALLING TRACK SUPPORT

Track lengths over 28 feet require the use of the track support. Table 3-1 provides the information for the track length, the distance from the bottom of the track to the building, and the location of the track support for various building heights. The base of track to building distance must be increased by the amount of any overhang on the building on which the hoist is being used.

Building Height	Length of Track	Base of Track to Building	Track Support Location —Cross Tie Number From Base of Track
40	44	10' 0"	20 <sup>th</sup>
36	40	9' 0"	18 <sup>th</sup>
32	36	8' 0"	15 <sup>th</sup>
28	32	7' 0"	13 <sup>th</sup>
24	28	6' 0"	Not Required
20	24	5' 0"	Not Required
16	20	4' 0"	Not Required
12	16	3' 0"	Not Required

**Table 3-1.**  
**Track Support Location Requirements**

1. Refer to Figure 3-6. Fasten the two knuckles provided in four places on the support mounting flanges using four 3/8 x 3/4" hex head cap screws, four 3/8" nuts, and four external tooth lock washers. Align the mounting holes on the knuckles and the support flanges that will make each knuckle flush with the end of the corresponding support flange.
2. See Figure 3-6, & refer to Table 3-1, to determine the cross tie on which to mount the support. With the track installed in its operating position against the building, use a ladder to raise the track support and knuckle assembly to the selected track cross tie. Fasten the track support knuckles to the cross tie using the provided lock pins.
3. Loosen the front and side lock screws at the top and/or bottom of the track support column to telescope the support to the ground, depending on how much support length you need. Retighten the lock screws.

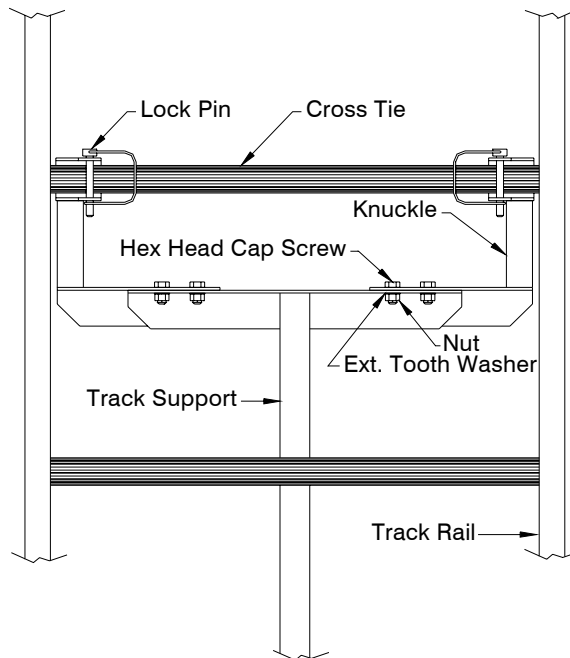

**Figure 3-6.**  
**Track Support Assembly**

## 4 OPERATION

### 4.1 BEFORE OPERATING THE HOIST



#### **WARNING:**

**A GOOD LINE OF COMMUNICATION MUST BE MAINTAINED BETWEEN THE HOIST OPERATOR AND THE ROOF CREW.**

1. Only trained personnel shall operate this equipment. A trained person is one who has read and thoroughly understands this instruction manual and related equipment manuals and, through training and experience, has shown knowledge regarding the safe operational procedures.
2. Obey all safety labels provided on your platform hoist and related equipment. These labels warn you of potential hazards that can cause serious injury. If a label comes off or becomes hard to read, contact Reimann & Georger Corporation for a replacement.
3. Follow the Pre-hoisting Checklist in the front of this manual before operating.
4. Never use the hoist structure to anchor lifelines, worker harnesses, or other attachments.
5. Always use safety footwear, safety glasses, and head protection devices.
6. Before lifting, insure the safety latch on the hook is not supporting any load. Never hoist over an open doorway.



#### **WARNING:**

**THE HOISTING OPERATION MUST BE CLEAR OF ALL ELECTRICAL LINES AND OBSTRUCTIONS TO PREVENT EQUIPMENT DAMAGE AND/OR SERIOUS PERSONAL INJURY. CONSULT POWER COMPANY BEFORE WORKING NEAR POWER LINES.**

7. Hoisting area is to be kept clear of unauthorized personnel. Place barricades or secure the area in such a manner that if there were an equipment failure, no personnel would be injured.
8. Inspect wire rope for damage, wear, or unraveling. Replace as necessary.
9. Check all hooks and sheaves. Replace as necessary.

### 4.2 RAISING AND LOWERING THE LOAD



#### **WARNING:**

**NEVER EXCEED THE RATED LOAD CAPACITY OF 200 POUNDS FOR THE PRO200 HOIST. THE RATED LOAD CAPACITY IS THE MAXIMUM LOAD THAT SHOULD EVER BE APPLIED TO THE HOIST.**



#### **WARNING:**

**SECURE THE LOAD BEFORE LIFTING.**



#### **WARNING:**

**NEVER STAND IN-LINE WITH THE RAISING OR LOWERING OF THE PLATFORM AT EITHER THE TOP OR BOTTOM OF THE HOIST TRACK.**

1. To raise the load, lift the operator handle slowly with a smooth upward motion. This automatically tightens the drive belt and releases the brake, permitting the platform to roll up the track.
2. When the platform reaches the top of the track, release the operator lever. This action stops the platform and automatically applies the brake, which holds the load and platform.



**WARNING:**  
**KEEP OUT FROM UNDER A RAISED LOAD.**



**WARNING:**  
**IF THE ENGINE OR MOTOR FAILS DURING OPERATION, RELEASE THE OPERATOR HANDLE TO PREVENT LOAD FROM FALLING.**

3. Do not allow the platform to jam against the spring stops on the top bracket. The drive belt may jam in the drum sheave, preventing the lowering of the platform.



**WARNING:**  
**DO NOT REMOVE MATERIAL FROM THE HOIST UNTIL IT HAS STOPPED COMPLETELY.**

4. Depress the operator handle to lower platform to the ground. **Lowering speed for SAFE operation should not exceed 50 feet/minute.** Continue to decelerate the platform as it nears the ground to prevent damage to platform or track. Do not allow the platform to strike the track shoes upon reaching the bottom of the track.



**WARNING:**  
**AVOID SUDDEN BRAKING WHEN HANDLING A LOAD.**

5. Check the hoist periodically during operation. Do not attempt to make adjustments during operation.



**WARNING:**  
**KEEP ALL BODY PARTS CLEAR OF MOVING PARTS.**

### 4.3 PREPARING HOIST FOR SHUTDOWN

At the end of operation, secure the equipment to prevent unauthorized use. **Never** assume you will find the equipment in the same condition that you left it. Proceed as follows:

1. Insure that all lifting tension has been removed from the wire rope.
2. Shut off PRO Drive and take necessary action to prevent its unauthorized use.
3. If the hoist is being permanently disassembled, at the end of a project for example, follow the detailed disassembly procedures in Chapter 5.

## 5 DISASSEMBLY

### 5.1 PRIOR TO DISASSEMBLY

1. Before disassembling the hoist, read and follow all the safety rules of this manual. Failure to do this can lead to equipment damage and/or serious personal injury.
2. Insure that the platform is not supporting any load before proceeding.
3. Before dismantling, attach a tie rope to hold the platform in position at the base of the track.
4. Insure the track is securely tied to the roof with a rope fastened to a cross tie or top bracket to prevent track from slipping.
5. Check carefully for proximity of power lines or other overhead obstructions.

### 5.2 REMOVING TRACK SUPPORT

1. Using a ladder, loosen the front and side lock screws at the top and/or bottom of the track support column to telescope the support into the flange. Re-tighten the lock screws.



#### **WARNING:**

**NEVER CLIMB ON THE TRACK FOR ANY REASON. THIS CAN CAUSE SERIOUS PERSONAL INJURY OR DEATH.**

2. Remove the track support from the cross tie by unfastening the lock pins.
3. If the track support will be used on the same hoist model in future applications, the knuckles do not have to be removed from the mounting flanges.

### 5.3 LOWERING THE TRACK

1. Unfasten the hoist wire rope from the hook provided on the platform. Pull the wire rope end through the sheave on the top bracket to unreeve, attach a tether rope to the wire rope, and lower it to the ground.



#### **WARNING:**

**WEAR HEAVY LEATHER GLOVES WHEN HANDLING WIRE ROPE. INSUFFICIENT HAND PROTECTION WHEN HANDLING WIRE ROPE CAN CAUSE SERIOUS PERSONAL INJURY.**

2. Attach a tether rope to the top bracket. Then untie the rope that fastens the track to the roof.
3. A person on the roof must lift up on the top bracket with the tether rope while a person on the ground moves the bottom of the track towards the building. When the track reaches a vertical position, the person on the ground may either:
  - (a) turn the track 90° and have the roof person lower the track with the ground person bracing their feet against the track shoes, or;
  - (b) turn the track 180°, move the bottom of the track against the building and have the roof person lower the track with the track shoes braced against the building.

In either case, the track must be turned to make the platform point upwards when the lowering operation is completed.

4. When the track has reached the ground, remove the tie rope holding the platform in position on the track.



#### **5.4 DISASSEMBLING THE TRACK SECTIONS**

1. Remove the top bracket from the end of the top track section.
2. Remove the installed hex nuts and bolts to separate each track section from the adjoining sections. Then roll the platform down and off the track in the direction opposite the track shoes.

## 6 INSPECTION AND MAINTENANCE

### 6.1 GENERAL MAINTENANCE RULES

1. Proper maintenance of the hoist and related equipment consists of adhering to all the guidelines given in this chapter and in the Pre-Hoisting Checklist in the front of this manual. Proper maintenance is required to maintain the system in good condition, which is defined as each part being free of rust or other corrosion, bends, breaks, or other defects.
2. Review and follow all the safety rules given in Chapter 1 before attempting any maintenance.
3. Only authorized personnel should be allowed in the maintenance area. Authorized personnel are the trained people as defined below and their supervision.
4. Repairs must be made only by trained personnel. A trained person is one who has read and thoroughly understands this instruction manual and related equipment manuals and, through training and experience, has shown knowledge regarding the safe operational procedures.



#### **WARNING:**

**WEAR HEAVY LEATHER GLOVES WHEN HANDLING WIRE ROPE. INSUFFICIENT HAND PROTECTION WHEN HANDLING WIRE ROPE CAN CAUSE SERIOUS PERSONAL INJURY.**

5. Do not weld or otherwise modify the hoist. Such alterations may weaken the structural integrity of the hoist and invalidate your warranty.



#### **WARNING:**

**DURING ANY ERECTION, MAINTENANCE, OR REPAIR PROCEDURES, DO NOT ATTEMPT ANY HOISTING. THIS CAN CAUSE EQUIPMENT DAMAGE AND/OR SERIOUS PERSONAL INJURY.**



#### **WARNING:**

**EXCEPT FOR MAINTENANCE AND REPAIRS THAT CANNOT BE DONE OTHERWISE, SHUT DOWN AND LOCK OUT THE PRO DRIVE TO PREVENT ACCIDENTAL STARTUP.**



#### **WARNING:**

**NEVER CLIMB THE TRACK TO DO MAINTENANCE. THIS CAN LEAD TO SERIOUS PERSONAL INJURY.**

### 6.2 INITIAL INSPECTION

Hoist erection and dismantling must be done by trained personnel only as defined in Section 6.1. Each time after setting up the hoist and before placing it in service, all parts of the structure, and other equipment must be thoroughly inspected by trained personnel as described in the remainder of this chapter.

### 6.3 DAILY INSPECTION

It is important that all the maintenance procedures outlined in the Pre-Hoisting Checklist in the front of this manual be done daily. Details on inspecting the wire rope are given in Section 6.5.

All broken, worn or defective parts must be repaired or replaced before startup.

## 6.4 SAFETY HOOKS

The hoist wire rope attaches to the safety hook mounted on the platform main frame. If the hook should become broken, bent, or disassembled, it should be replaced immediately.

## 6.5 WIRE ROPE INSPECTION PROCEDURE

Inspect the wire rope prior to each use and at least daily for signs of wear, damage, or pinching. Inspect the entire wire rope working length. Thoroughly inspect the rope sections that pass over sheaves or drums, or that make opposing turns. Inspect wire rope and end attachments carefully. While inspecting, examine sheaves, guards, guides, drums, flanges, and other surfaces contacting wire rope during operation. Correct any condition harming the rope in use or other damage or worn surfaces at this time.

Remove or replace immediately wire rope with one or more of the following defects:

1. Corrosion
2. Broken wires:
  - (a) One or more valley breaks. A valley break is a wire break occurring in the valley between two adjacent strands.
  - (b) Six randomly distributed broken wires in one rope lay. A rope lay is the length of rope along which one strand makes a complete revolution around the rope. See Figure 6-1. Keeping the rope clean and wound evenly on the drum will increase its life and efficiency.
  - (c) Abrasion: Scrubbing, flattening or peening causing loss of more than one-third of the original diameter of the outside wires.
3. Kinking: Severe kinking, crushing, bird caging or other damage causing distortion of the rope structure. Bird caging is a bulging in the wire rope caused by the individual wires becoming untwisted. This untwisting of individual wires is usually caused by impact loading on the wire rope (such as a sudden stop).
4. Heat damage: Evidence of any heat damage caused by a torch or by contact with electrical wires.
5. Reduction of more than 1/64 inch from a nominal 5/32-inch or less diameter wire rope.

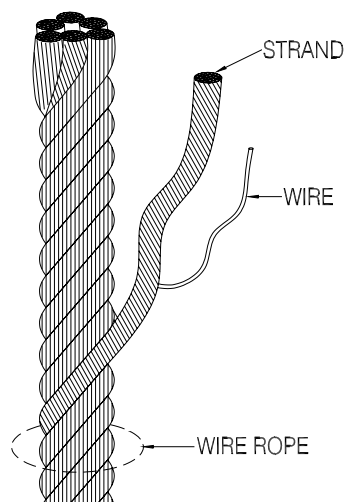

**Figure 6-1.**  
**Wire Rope Components**

## 7 TROUBLESHOOTING

The following chart is intended to assist with troubleshooting the platform hoist. While not all inclusive, the chart outlines the most common causes of a problem and the recommended course of action.

SYMPTOM	CAUSE AND CORRECTIVE ACTION
<p>Hoist won't lift load or is lifting it very slowly</p>	<p>No oil in engine to build compression—must add oil. Refer to PRO Drive manual for further information.</p> <p>Hoist attempting to lift more than stated capacity of unit—check capacity rating and reduce load weight as needed.</p> <p>Brake is dragging which may cause a “squealing” noise.</p> <p>Platform not moving freely—check for track obstructions or block and wire rope malfunctions.</p> <p>Engine related problems—refer to PRO Drive manual. Reference to manufacturer's instruction manual may also be necessary.</p> <p>On electric motors, extension cord too long, which can cause reduced voltage input—shorter cord or heavier gauge wire must be used.</p> <p>Engine speed too slow—increase throttling.</p> <p>Too much wire rope on drum—hoisting capacity decreases as wire rope diameter increases.</p>
<p>Platform will not lower.</p>	<p>Platform has been allowed to jam against the spring stops on the top bracket causing the drive belt to jam in the drum sheave—shut off the gas engine or electric motor. Then release the jammed belt by inserting a screwdriver between the belt and the sheave groove.</p>

## 8 PARTS LISTS

Each item number on the following parts lists can be matched with the item number shown on the corresponding assembly drawing as indicated below.

Refer to Figure 8-1.

Item Number	Part Number	Quantity	Description
1	0401110	1	TOP SHEAVE BRACKET
2	0400575	2	SPRING, BOLT & NUT – TOP SHEAVE
3	0401424	1	TOP SHEAVE BRACKET MTG HDWR KIT consisting of 4ea carriage bolt & wing nut
4	0420405		CROSS TIE BRACE*
5	0401290	1	PLATFORM FLIPPER
6	0401260	1	MAIN FRAME
7	0401280	1	PLATFORM RIGHT BRACE
8	7300653	1	SNAP SAFETY HOOK
	5805910	1	U-BOLT
	5806367	2	LOCKNUT
9	0401214	8	TROLLEY WHEEL KIT*
10	7806008	1	BUMPER
11	0420401	2	TRACK SWIVEL SHOE MTG BRKT*
12	0420402	2	TRACK SWIVEL SHOE*
13	0420404		CROSS TIE STIFFENER
14	0404804	6	GUIDE ROLLER WHEEL KIT*
15	0401285	1	PLATFORM LEFT BRACE
16	0401270	1	PLATFORM TOP
17	0401255	1	HARDWARE BAG FOR ITEMS 5, 7, 15, & 16
18	0400828		TRACK SPLICE PLATE
19	7303600	1	SHEAVE
	5806326	1	CARRIAGE BOLT
	5806370	1	LOCKNUT
	5800831		TRACK SPLICE PLATE NUT & BOLT
	0482800		TRACK SPLICE PLATE KIT consisting of: 2 splice plates, 8ea nut & bolt
	0401498		TRACK SWIVEL SHOE CONVERSION KIT* from PL series to PRO series consisting of: 2 shoes & 2 mounting brackets

**\*HARDWARE INCLUDED**

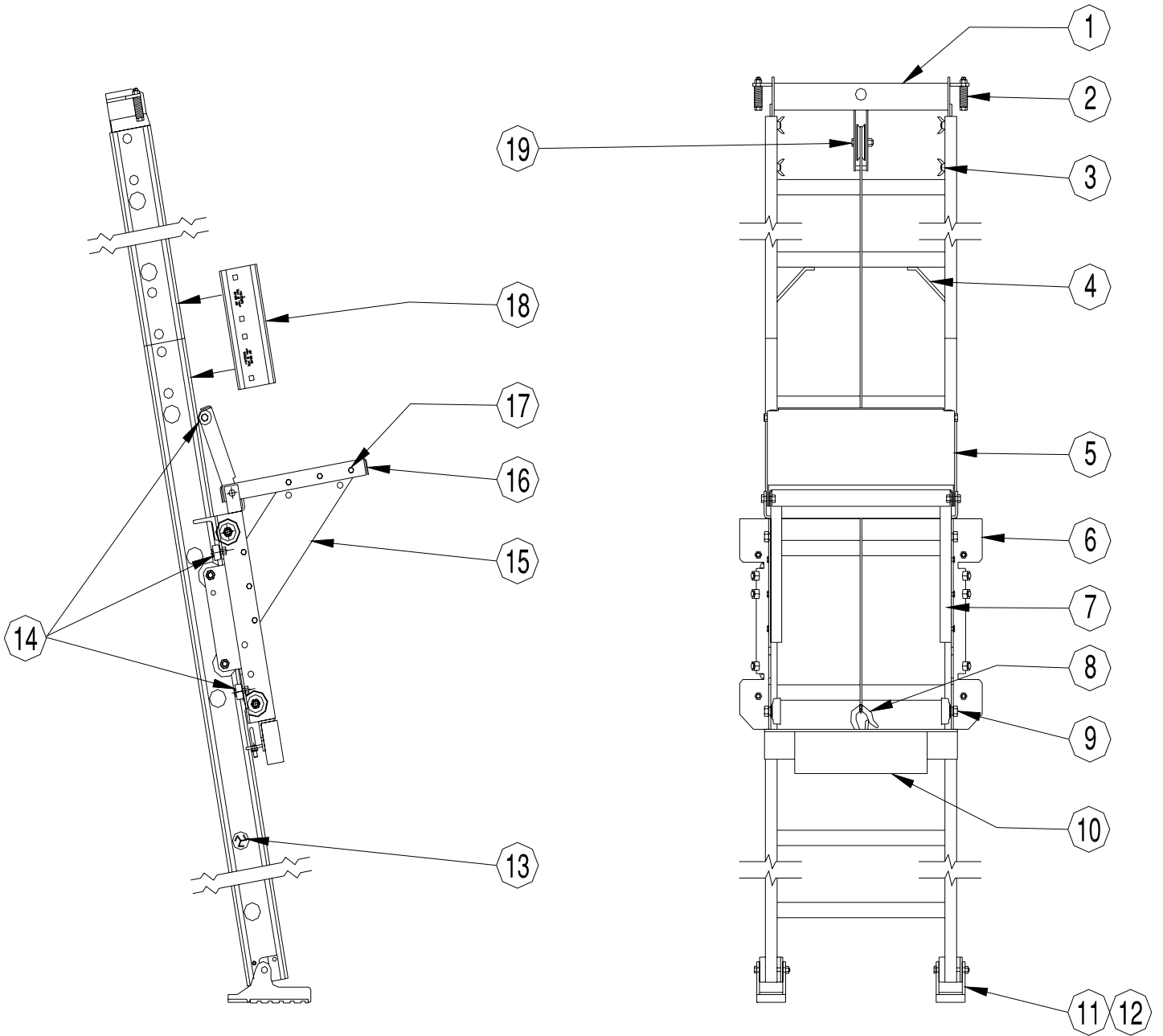

**Figure 8-1.**  
**Assembly Drawing**